



Jones, M. P. A., Vale, C. J., & Sahagun, D., et al. (2007). Cold atoms probe the magnetic field near a wire.

Originally published in *Journal of Physics B: Atomic, Molecular, and Optical Physics*, 37(2), L15–L20.

Available from: <http://dx.doi.org/10.1088/0953-4075/37/2/L01>.

Copyright © 2004 IOP Publishing Ltd.

This is the author's version of the work. It is posted here with the permission of the publisher for your personal use. No further distribution is permitted. If your library has a subscription to this journal, you may also be able to access the published version via the library catalogue.

The definitive version is available at <http://iopscience.iop.org/>.



Cold atoms probe the magnetic field near a wire

M P A Jones, C J Vale[‡], D Sahagun, B V Hall, C C Eberlein[‡],
B E Sauer, K Furusawa^{*}, D Richardson^{*} and E A Hinds

Blackett Laboratory, Imperial College, London SW7 2BW, UK

[‡]Department of Physics and Astronomy, Sussex University, Falmer, BN1 9QH, UK

^{*} Optoelectronics Research Centre, Southampton University, Southampton, SO17 1BJ, UK

E-mail: ed.hinds@ic.ac.uk

Abstract. A microscopic Ioffe-Pritchard trap is formed using a straight, current-carrying wire, together with suitable auxiliary magnetic fields. By measuring the distribution of cold rubidium atoms held in this trap, we detect a weak magnetic field component ΔB_z parallel to the wire. This field is proportional to the current in the wire and is approximately periodic along the wire with period $\lambda = 230 \mu\text{m}$. We find that the decrease of this field with distance from the centre of the wire is well described by the Bessel function $K_1(2\pi y/\lambda)$, as one would expect for the far field of a transversely oscillating current within the wire.

PACS numbers: 03.75.Be, 34.50.Dy, 72.15.-v, 03.75.Hh

[‡] Current address: Dept. of Physics, University of Queensland, Brisbane 4072, Australia.

1. Introduction

The ability to control cold atom clouds in microscopic magnetic traps [1, 2, 3] and waveguides [4, 5, 6] has created the new field of miniaturized atom optics [7, 8]. With the use of microstructured surfaces (atom chips) it becomes possible to control cold atoms on the μm length scale and to anticipate the construction of integrated atom interferometers [9, 10, 11]. Ultimately there is the possibility of controlling the quantum coherences within arrays of individual atoms for use in quantum information processing [12, 13]. For these kinds of applications it is important to avoid fluctuating or inhomogeneous perturbations, which tend to destroy the quantum coherences.

Cold atom clouds cooled below a few μK have recently been used to probe the magnetic field fluctuations within $100\ \mu\text{m}$ of a current-carrying wire. Two frequency domains have been studied. Audiofrequency fluctuations of the currents that form the microtraps can excite centre-of-mass vibrations of the atoms [10, 14], causing the cloud to heat up. Radiofrequency noise in the wire currents can drive spin flips, which cause atoms to be ejected from the trap [10, 14]. Usually this noise is due to technical imperfections of the apparatus, as elucidated by Leanhardt *et al.* through a comparison of magnetic and optical traps near a surface [15]. However, there is also a fundamental component of the magnetic field noise in the near-field of the wire, which is due to thermal fluctuations of the current and has recently been measured in our laboratory [16].

The dc behaviour of the field is less well understood. As the atom cloud is brought close to the main current-carrying wire of the trap it breaks into fragments along the length of the wire [14, 17, 16], indicating an unexpected variation in the trapping potential. Kraft *et al.*[18] have recently shown that this is due to the presence of a magnetic field component ΔB_z *parallel* to the wire that varies along the length of the wire. In this paper we use cold atoms held in a microtrap close to a wire to measure ΔB_z and to explore how it varies in the vicinity of the wire.

2. Preparation of cold atoms

The arrangement of wires used to form our microtrap is shown in figure 1. The main wire is a $500\ \mu\text{m}$ diameter guide wire along the z -direction. In cross section it has a $370\ \mu\text{m}$ diameter copper core, surrounded by an aluminium layer $55\ \mu\text{m}$ thick with a $10\ \mu\text{m}$ thick ceramic outer coating. This wire is glued by high-vacuum epoxy (Bylapox 7285) into the $200\ \mu\text{m}$ -deep channel formed by a glass substrate and two glass cover slips. Below the guide wire there are four transverse wires, each $800\ \mu\text{m}$ in diameter. The cover slips are coated with $60\ \text{nm}$ of gold so that they reflect $780\ \text{nm}$ light. In order to load cold atoms into the microtrap we first collect ^{87}Rb atoms using a magneto-optical trap whose beams are reflected from the gold surface. This MOT collects 1×10^8 atoms at a height of $4\ \text{mm}$ above the surface and cools them to $50\ \mu\text{K}$. The MOT is pulled down to a height of $1.3\ \text{mm}$ by passing a current of $3.2\ \text{A}$ through the guide wire and adding

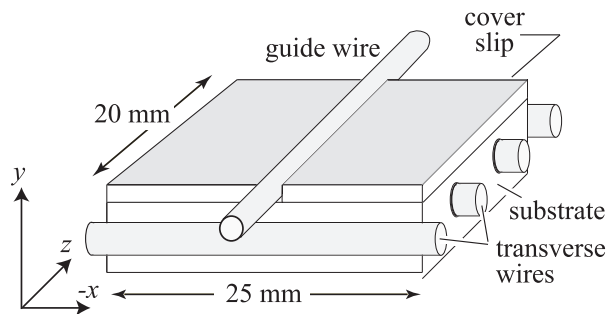

Figure 1. Construction of the magnetic microtrap (not to scale). A current along z and a bias field along x together form a long thin trap parallel to the guide wire. The ends of the trap are closed by currents in the transverse wires. Atoms are trapped near the surface of the guide wire.

a uniform magnetic field B_x^{bias} of 6 G along the x -direction. This compresses the cloud into a cylindrical shape and increases the phase space density of the atoms to 2×10^{-6} [19].

The light and the anti-Helmholtz coils of the MOT are then switched off and the atoms are optically pumped into the $|F, m\rangle = |2, 2\rangle$ state. We collect 2×10^7 of these atoms in the magnetic guide formed by the guide wire (8 A along z) and the transverse bias field B_x^{bias} (10 G along x). Axial confinement is provided by the inner transverse wires (15 A each along $-x$) and the outer transverse wires (15 A each along x). The field at the centre of this trap is partly cancelled by an axial bias field B_z^{bias} (6 G along z). Next, the trap is adiabatically compressed over 0.5 s by increasing B_x^{bias} and B_z^{bias} to 29 G and 11 G respectively, and reducing the guide current to 6.9 A. This brings the trap to a height of $225 \mu\text{m}$ above the top of wire and reduces the net field along z at the centre of the trap to ~ 1 G. In this way, the radial and axial trap frequencies are raised to 840 Hz and 26 Hz. The elastic collision rate is now $\sim 54 \text{s}^{-1}$, which is high enough for forced rf evaporative cooling to be efficient. We sweep the rf frequency logarithmically over 6 s from 13 MHz to a final frequency near 2.8 MHz, cooling the cloud down to approximately $6 \mu\text{K}$. This temperature is a good choice because it gives the atoms a thermal kinetic energy comparable with the potential created by ΔB_z that we wish to probe. The atoms are brought closer to the surface by a smooth reduction of the current flowing in the guide wire during the last 1 s of evaporation. The arrival of the atoms at the desired height coincides with the end of the evaporation ramp.

The cloud is viewed using a ccd camera to record the absorption of a resonant probe beam propagating along the x -direction. Two images are recorded, one with the atoms present and one without, and we compute the logarithm of their ratio. Since the cloud is optically thin, this procedure yields an image of the column density of the atoms, viewed in the $y - z$ plane. Integrating this over y , gives the probability distribution of atoms along the z -direction. Let us call it $\rho(z)$. Assuming that the gas is in thermal equilibrium at temperature T , $\rho(z)$ is related to the confining potential $U(z)$ by the Boltzmann factor $\exp(-U(z)/kT)$. In the absence of ΔB_z , the potential $U(z)$ is

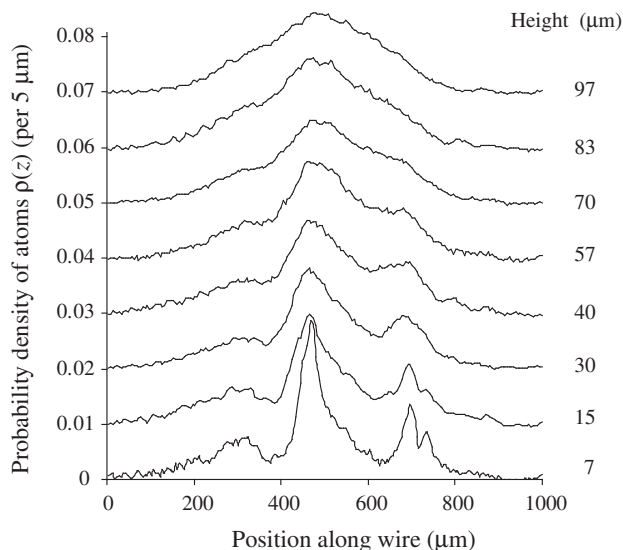

Figure 2. Distribution of atoms $\rho(z)$ along the length of the Ioffe-Pritchard trap for a variety of distances between the atoms and the guide wire. The curves show the probability of finding atoms within a range $\delta z = 5\mu\text{m}$ and are all normalized to unit total probability. They are successively offset by 0.01 for the sake of clarity. Far from the wire, the distribution is Gaussian, but at closer distances the cloud develops additional structure and can break into lumps

harmonic with an axial frequency of 26-27 Hz over the range of heights studied. Fitting a parabola to $-\ln \rho(z)$ then determines the temperature T . For example, the top curve in figure 2 taken $97\mu\text{m}$ above the surface of the wire gives $T = 5.8\mu\text{K}$.

3. Fragmentation

When the cloud is brought closer to the surface, the distribution $\rho(z)$ develops additional structure, as can be seen in figure 2. Similar behaviour has been reported by other groups studying atoms near copper wires [14, 17]. This indicates that the atoms experience some other interaction near the surface in addition to the expected simple harmonic potential of the trap. Kraft *et al.* have recently shown that this is due to a magnetic field component ΔB_z parallel to the wire [18]. Where this field adds to (reduces) the axial bias field of the magnetic trap there is an increase (decrease) of $\mu_B \Delta B_z$ in the potential energy of the trapped atoms. To obtain ΔB_z for each curve in figure 2, we first derive the temperature T from the parabola fitted to $-\ln \rho(z)$. This parabola is chosen to pass through the centre of the ΔB_z oscillations. For the 8 curves shown the temperature is nearly constant, being (5.8, 6.1, 6.4, 7.0, 7.8, 7.8, 7.8, 7.8) μK , with the variations arising from slight differences in the final stage of the evaporation trajectories. The difference between $-\ln \rho(z)$ and the fitted harmonic potential is the potential of interest $\Delta B_z/kT$, and since we know T from the harmonic fit, we obtain ΔB_z . In this

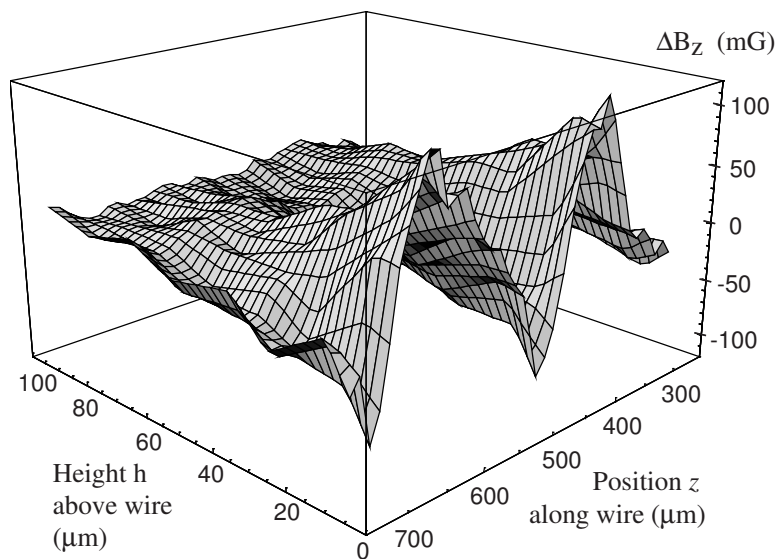

Figure 3. Anomalous magnetic field ΔB_z as a function of position for a current of 3.7 A in the guide wire.

way we have measured how ΔB_z varies along z at the 8 different heights h of the cloud above the wire.

The height of the cloud above the surface is set by adjusting the current in the guide wire, keeping the bias field B_x^{bias} fixed at 29 G. For the largest and smallest heights presented in figure 2 ($97 \mu\text{m}$ and $7.2 \mu\text{m}$) the guide wire currents are 5 A and 3.7 A respectively. ΔB_z is proportional to the current in the guide wire [18], so to compare ΔB_z at different heights we scale the result at each height to the current used. Figure 3 is a map of $\Delta B_z(y, z)$ scaled to a fixed 3.7 A in the guide wire. The surface shown interpolates between the 8 heights where measurements were made.

We see ΔB_z undergoing 2 full periods of oscillation along the wire. The phase of the oscillation is fixed with respect to the wire and did not change over several months of experiments. The field has many more oscillations along the wire, with an average wavelength λ of $230 \pm 10 \mu\text{m}$, but in this particular experiment the atoms are confined to these two periods by the trap potential. It would seem that the current, or perhaps the electron spin [14, 18], follows an oscillatory or helical path along the wire with wavelength λ . This could be due to some fundamental physics, or perhaps to a regular arrangement of impurities or defects in the wire. In any such case, the decay of the field component ΔB_z with distance y should be well approximated by the modified Bessel function $K_1(ky) \sim \exp(-ky)/\sqrt{ky}$, provided the distance y from the current to the atoms is much greater than the transverse excursions of the current. The quantity k is $2\pi/\lambda$. In order to test this idea we have measured the amplitude of the ΔB_z oscillations at each height h above the wire and these points are plotted in figure 4. The solid line is a least-squares fit to the function $aK_1(2\pi(h+\delta)/\lambda)$, in which a , δ , and λ were allowed to vary freely as fitting parameters. The best fit has a χ^2 of 4.8 for 5 degrees of freedom and gives the results $\lambda = 217 \pm 10 \mu\text{m}$ and $\delta = 251 \pm 12 \mu\text{m}$. The close agreement

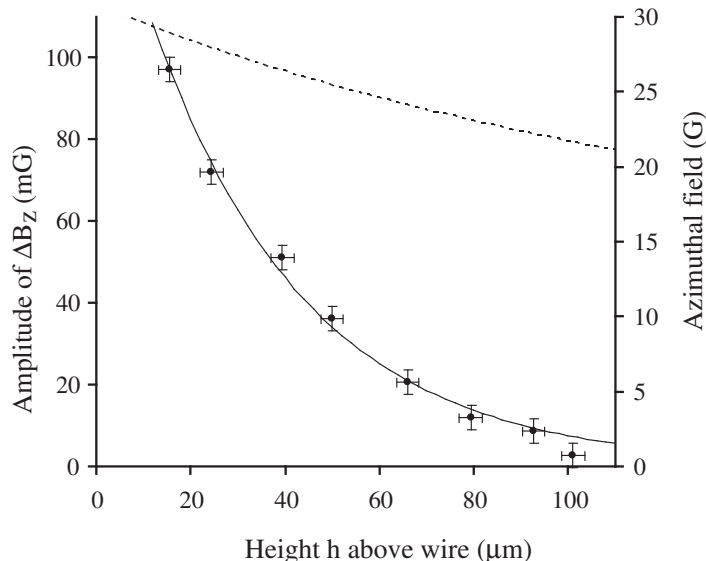

Figure 4. Magnetic fields versus height h above a wire carrying 3.7 A. Data points: amplitude of the anomalous magnetic field variation ΔB_z . Solid line: best fit of the modified Bessel function $aK_1(2\pi(h + \delta)/\lambda)$. This has $\lambda = 217 \pm 10 \mu\text{m}$ and $\delta = 251 \pm 12 \mu\text{m}$. Dashed line: The (usual) azimuthal field referred to the auxiliary ordinate on the right.

between this value of λ and the value of $\lambda = 230 \pm 10 \mu\text{m}$ obtained directly from the images strongly suggests that our model is correct. The value of δ is equal to the wire radius indicating that the centre of the oscillating current coincides with the centre of the wire.

The dashed curve in figure 4 shows the usual magnetic field produced by 3.7 A in a wire, which varies inversely with the distance from the centre of the wire. Expressed as a fraction of this field, the amplitude of the ΔB_z oscillations ranges from 3×10^{-3} to 3×10^{-4} over the heights studied. This ratio provides information about the transverse excursion of the effective current. For example, if we suppose that the current is helical with an effective radius of r , the ratio of field components has the value $k^2 r y K_1(ky)$, which implies that $r = 50 \mu\text{m}$. A similarly large amplitude is found for other possible motions (e.g. planar or random walk with characteristic length scale). The Lorentz forces due to the applied magnetic fields do not generate enough transverse current to account for this. Nor do the variations in the shape and centre of the wire. Microscopic structure within the wire was revealed by polishing and etching a longitudinal section of the wire following standard metallographic methods. In the copper we found grains of $\sim 10 \mu\text{m}$ and in the aluminium we found small defects typically spaced by $\sim 5 \mu\text{m}$. Neither of these provides a plausible explanation for the transverse current. We therefore remain unable to propose a mechanism for the observed variation of the current.

The exponential character of the decay means that ΔB_z decreases too rapidly with

distance to be described by a power law. The Tübingen group, who proposed a power law ansatz [18], have kindly provided us with their data [20] taken above a $90\ \mu\text{m}$ diameter copper wire and we find that it is also well described by the K_1 Bessel function.

4. Conclusions

We have investigated the behaviour of a cloud of cold trapped atoms brought close to the surface of a current-carrying wire. As the atoms approach the wire, the cloud breaks into fragments due to the presence of an anomalous magnetic field parallel to the wire. Analysis of the density distribution of the atoms has allowed us to make a quantitative map of this anomalous field. Along the wire it oscillates with a period of $230\pm 10\ \mu\text{m}$ and with increasing radius it decays according to a modified Bessel function K_1 . We point out that this behaviour is characteristic of the field produced by a periodic transverse current distribution in the wire. We have found a characteristic decay length of $217\pm 10\ \mu\text{m}$, in good agreement with the observed period and we have shown that the anomalous current is centred on the middle of the wire. Despite some effort, it remains unclear why the current should move in this way.

Acknowledgments

We are indebted to Alan Butler and John Knight for expert technical assistance. We also thank József Fortágh for helpful discussions and for providing us with data from the Tübingen experiment. This work was supported by the UK Engineering and Physical Sciences Research Council, and by the FASTNET and Cold Quantum Gases networks of the European Union.

References

- [1] J. D. Weinstein and K. G. Libbrecht, *Phys. Rev. A* **52**, 4004, (1995).
- [2] V. Vuletic *et al.*, *Phys. Rev. Lett.* **80**, 1634, (1998).
- [3] J. Fortágh *et al.*, *Phys. Rev. Lett.* **81**, 5310, (1998).
- [4] D. Müller *et al.*, *Phys. Rev. Lett.* **83**, 5194, (1999).
- [5] N. H. Dekker *et al.*, *Phys. Rev. Lett.* **84**, 1124, (2000).
- [6] M. Key *et al.*, *Phys. Rev. Lett.* **84**, 1371, (2000).
- [7] E. A. Hinds and I. G. Hughes, *J. Phys. D* **32**, R119, (1999).
- [8] R. Folman *et al.*, *Adv. Atom. Mol. Opt. Phys* **48**, 263, (2002).
- [9] E. A. Hinds, C. J. Vale and M. G. Boshier, *Phys. Rev. Lett.* **86**, 1462, (2001).
- [10] W. Hänsel *et al.*, *Phys. Rev. A* **64**, 063607, (2001).
- [11] E. Andersson *et al.*, *Phys. Rev. Lett.* **88**, 100401, (2002).
- [12] T. Calarco *et al.*, *Phys. Rev. A* **61**, 022304, (2000).
- [13] P. Horak *et al.*, *Phys. Rev. A* **67**, 043806, (2003)
- [14] J. Fortágh *et al.*, *Phys. Rev. A* **66**, 041604(R), (2002).
- [15] A. E. Leanhardt *et al.*, *Phys. Rev. Lett.* **90**, 100404, (2003).
- [16] M. P. A. Jones *et al.*, *Phys. Rev. Lett.* **91**, 080401, (2003).
- [17] A. E. Leanhardt *et al.*, *Phys. Rev. Lett.* **89**, 040401, (2002).
- [18] S. Kraft *et al.*, *J. Phys. B* **35**, 469, (2002).

- [19] M. P. A. Jones, D.Phil. Thesis, University of Sussex, (2002).
- [20] J. Fortágh, PhD Thesis, University of Tübingen, (2003).